

LIGHT

tulux



# SWISS LIGHT CREATIONS

LEAN

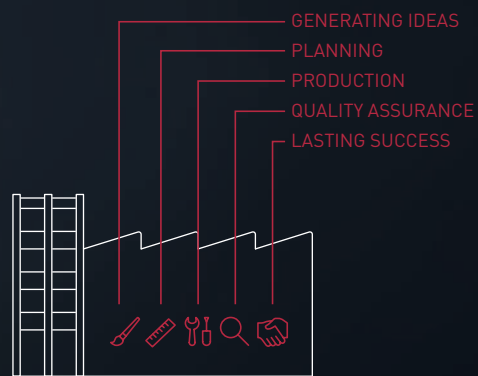
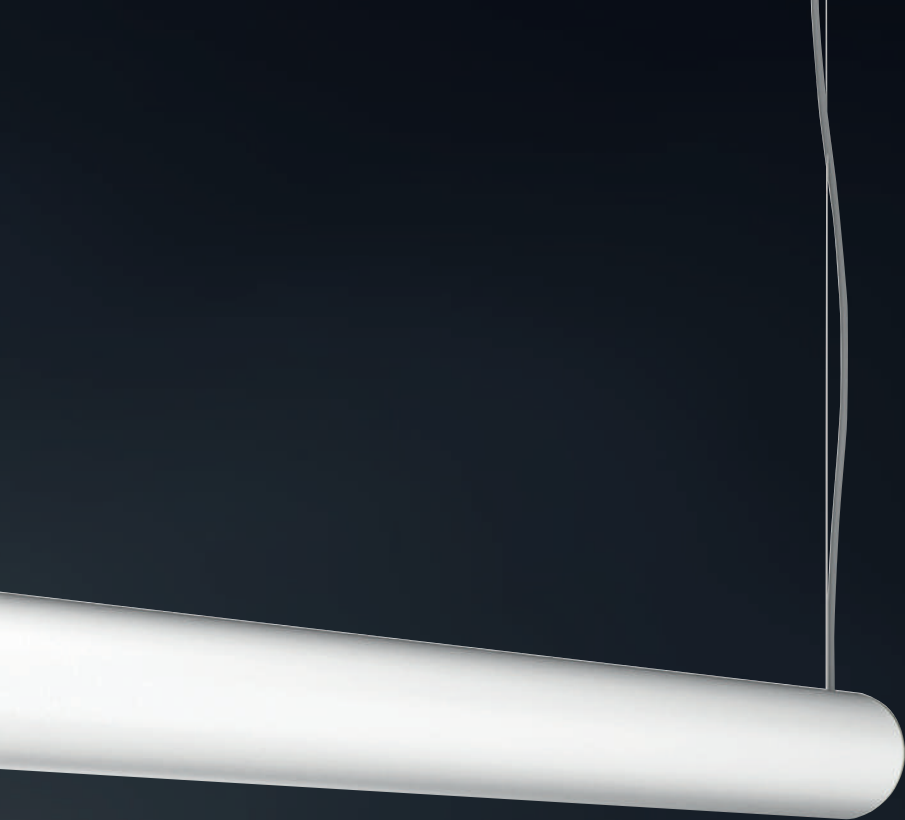

Tulux – a company  
that inspires.

## SWISS LIGHT CREATIONS



“Reliability and quality. This is what SWISS LIGHT CREATIONS stands for – and has done since 1948. We invest a great deal in these values – right here in Switzerland, at our production site in Tuggen in the canton of Schwyz. 200 members of staff ensure that genuine Swiss quality is reflected in every stage of the production process. From the idea through to the development, planning and successful implementation, we create lighting solutions that trigger emotions, because they are high quality and because they are truly SWISS LIGHT CREATIONS.

Decades of company tradition commit us to constant innovation. This requires courage, clarity and responsibility: the courage to create new solutions, clarity in implementation, and a responsibility to our staff and to society. That's why we live up to our responsibilities as a manufacturer and play an active role in recycling; after all, lights and lighting should not only be produced in high quality, they should also be able to be returned and recycled properly throughout Switzerland. As an SME, we are a significant player in the market. This is a position that comes with obligations. We take responsibility for our entire industry and bring new meaning to the word quality.

We design light, giving it form and an individual radiance. Rather than an arbitrary set of products, SWISS LIGHT CREATIONS stands for precise, convincing solutions. Our developers create not only high-quality standard luminaires but also special luminaires according to customer requests. Our development focuses on lights and lighting systems for the Swiss market. And, judging from the market's appreciation for what we do, we feel that our claims are justified and that we deliver precisely what we represent: SWISS LIGHT CREATIONS.”

A handwritten signature in black ink, appearing to read 'Ivo Huber', written in a cursive style.

Ivo Huber  
Managing Director

# LEAN

## Contents

- 5 **Five convincing reasons.**
- 6 **An idea that became reality.**
- 8 **A product that wins people over.**
  - 8 Overview
  - 10 Design
  - 11 Customisation
  - 12 Construction
  - 13 Light quality
  - 14 Light distribution
  - 15 Installation
  - 16 Applications



LEAN – five convincing reasons.

1. **Homogeneous, high-quality illumination**
2. **Entire technology integrated**
3. **Install and combine in different ways**
4. **Subtle and sophisticated**
5. **Objects illuminated all around**

LEAN – an idea  
that became reality.

# ADVICE AND SUPPORT

“Why am I so fascinated by LEAN? Quite simple: LEAN is modest and discreet, yet at the same time highly versatile. The restrained design can even inspire to use LEAN in creative ways, and I can see LEAN in schools, offices or reception areas. It appears simple wherever it is used, but nonetheless has a presence. It’s not a matter of chance that LEAN has these qualities – they are based on the experience of our in-house development and construction teams, who, for example, have succeeded in concentrating the entire technology of LEAN into the smallest space. LEAN clearly embodies what SWISS LIGHT CREATIONS stands for: reliability and quality.”

Roland Simonet  
Lighting Technology Consultant







LEAN – a product  
that wins people over.

# OVERVIEW

- Tube made of diffuse satinated acrylic glass
- Front side made of nickel silver pearl matt
- Slender ceiling bracket
- IP50/IP54 luminaire
- CRI > 90

Vertical suspension



Horizontal suspension



Standard lamp



Desk luminaire







Ceiling-mounted



Wall-mounted



Desk luminaire



Standard lamp



Wall



Ceiling



Horizontal suspension



Vertical suspension



Suspension configured per request

	Desk luminaire	Standard lamp	Wall	Ceiling	Horizontal suspension	Vertical suspension	Suspension configured per request
<b>Light colour</b>							
3000 K/ CRI > 90	•	•	•	•	•	•	•
4000 K/ CRI > 90	•	•	•	•	•	•	•
<b>Light output</b>							
Deep			•	•	•	•	•
Medium	•	•	•	•	•	•	•
<b>Installation type</b>							
Surface-mounted			•	•			
Suspended					•	•	•
<b>Dimensions</b>							
320 x 80 [100]			•				
610 x 80 [100]			• 1)				
900 x 80 [100]			• 1)				
1190 x 80 [100]				• 1)			
1480 x 80 [100]				• 1)			
1770 x 80 [100]				• 1)			
350 x 100						•	
360 x 100 [130]	•						
630 x 100						•	
910 x 100						•	• [6]*
1190 x 100					•	•	• [5]*
1470 x 100					•		• [4]*
1480 x 100 [240]		•					
1750 x 100					•		• [3]*
1760 x 100 [240]		•					
2310 x 100					•		

1) = Protection IP54 (x)\* = Maximum number of luminaires one below the other.

LEAN – a product  
that wins people over.

# DESIGN

- Light in its pure form
- Timeless, elegant line
- Inlaid front cover discretely seals the tube
- Ceiling console makes the luminaire appear to float
- Reduced form fits in perfectly with any style of architecture



LEAN – a product  
that wins people over.

# CUSTOMISATION

- Separate direct-indirect control
- Integrated emergency lighting possible
- Lighting installation can be configured

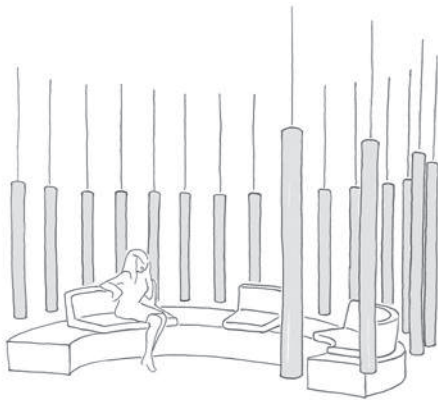

Architectural lighting feature

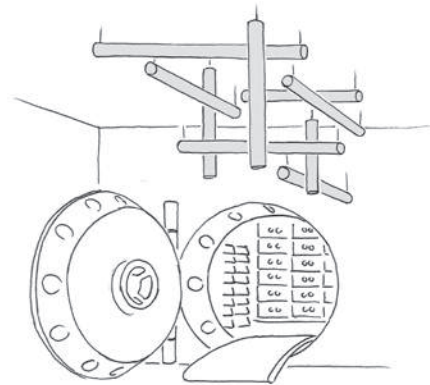

Lighting the way

LEAN – a product  
that wins people over.

# CONSTRUCTION

- Central aluminium profile serves as a load-bearing element
- Entire technology integrated
- Invisible suspension
- Tube diameter adjusted to light requirements

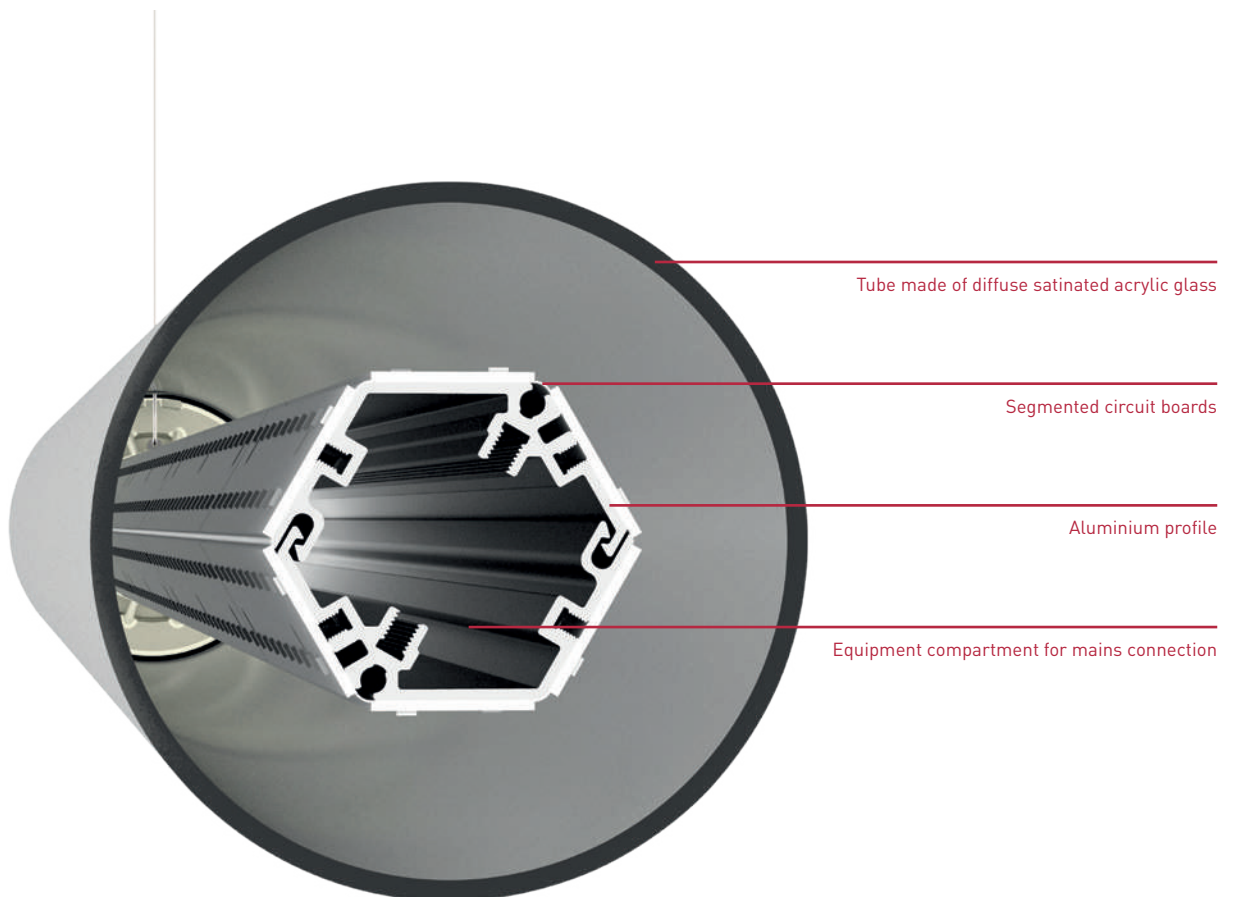



LEAN – a product  
that wins people over.

# LIGHT QUALITY

- Glare rating less than UGR 21
- 3000 K/4000 K colour rendering, CRI > 90
- Perfectly illuminated
- Subtle ceiling illumination for a comfortable light



LEAN – a product  
that wins people over.

# LIGHT DISTRIBUTION

- Optimised light output for suspension and surface-mounting
- Suitable from 100 to 500 lx
- Suitable from 600 to 12000 lm

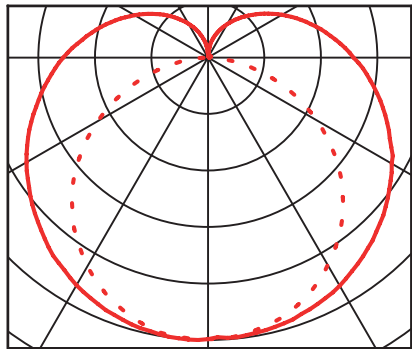

Ceiling luminaire

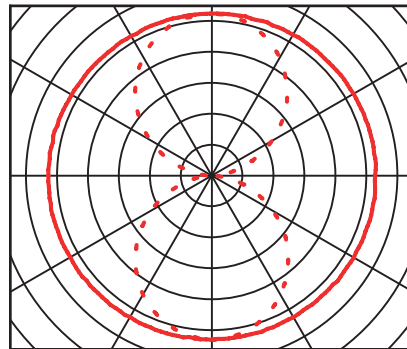

Pendant luminaire horizontal

LEAN – a product  
that wins people over.

# INSTALLATION

- Surface-mounted and pendant luminaires can be mounted in any position
- Pendant luminaires available in a vertically combinable version (possible up to 15m)
- Surface-mounted luminaire panel for pre-installation
- Combinable pendant luminaires ready for pre-assembly
- Easy access for installation and service



LEAN – a product  
that wins people over.

# APPLICATIONS

- Stairways
- Access areas
- Reception areas
- Treatment and therapy rooms
- Restaurants
- Classrooms
- Kindergartens
- Sport facilities (changing rooms)
- Bathrooms
- Kitchens
- Offices
- Covered outdoor areas
- Zones exposed to humidity



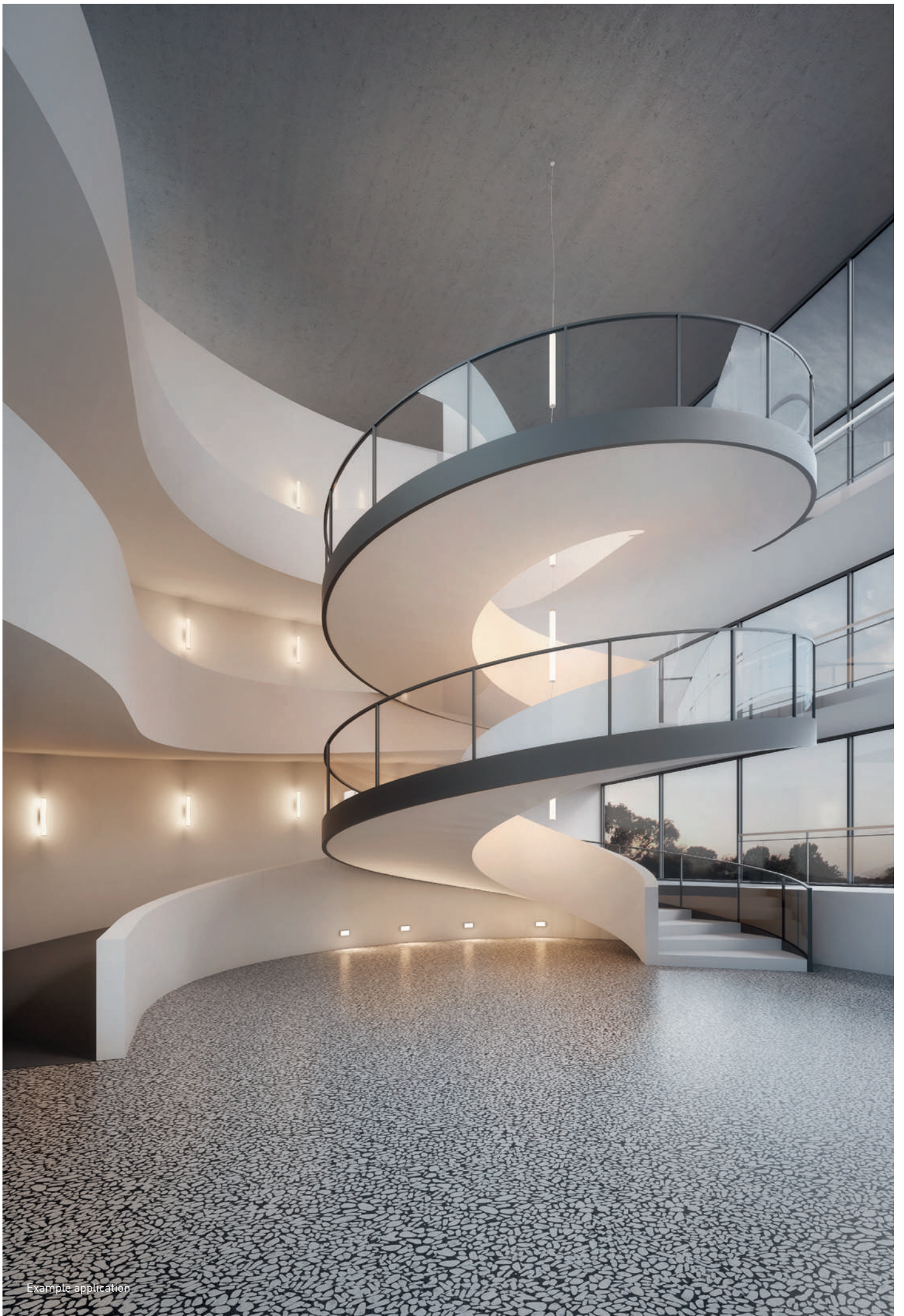

Example application





Example application



Example application





TULUX AG  
TÖDISTRASSE 4  
CH-8856 TUGGEN  
T +41 55 465 60 00  
F +41 55 465 60 01  
INFO@TULUX.CH

[WWW.TULUX.CH](http://WWW.TULUX.CH)



July 2020